



B-TECH AV MOUNTS™

# BT882

## PROJECTOR CEILING MOUNT

### WITH ADJUSTABLE DROP

INCREMENTED  
 TILT ADJUSTMENT  
 UP TO +/-90°

Designed for projectors up to 10kg, this projector mount is ideal for angled or cathedral ceilings. The BT882 features a unique 'carousel' mounting plate for universal compatibility and a ball joint adjustment that allows easy positioning so a perfectly aligned projection can be achieved. With a maximum ceiling drop of 830mm, a hand lever provides easy adjustment of the drop once the mount has been fixed into place. Installation is simple with all mounting hardware and fixings supplied, including coverplates for a smart and tidy finish.

#### SPECIFICATION

Max load	10kg
Tilt (pitch)	+/-90°
Roll	+/-90°
Yaw	360°
Ceiling drop	580 - 830mm
Max distance between fixings	340mm
Colour option	Black or White

#### FEATURES

- Designed to mount LCD/LED/DLP projectors up to 10kg
- Features +/-90° tilt, +/-90° roll and 360° swivel so that a perfectly aligned projection can be achieved
- Unique 'carousel' mounting plate for universal compatibility
- Ball joint adjustment for easy positioning of projector
- Hand lever for easy adjustment of ceiling drop, from 580mm to 830mm
- Quick and easy installation
- Cover plates included for a smart installation
- Steel safety wire included for extra security
- Suitable for projectors with M2.5, M3, M4, M5 and M6 fixings
- All mounting hardware included

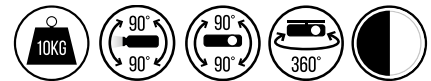

Unique 'carousel' mounting plate for universal compatibility



Hand lever for easy adjustment of ceiling drop, from 580mm to 830mm



Ball joint adjustment for easy positioning of projector



Ideal for angled or cathedral ceilings

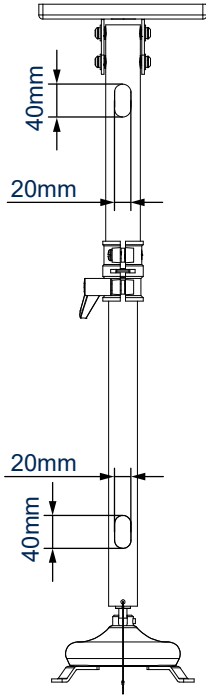

FRONT VIEW

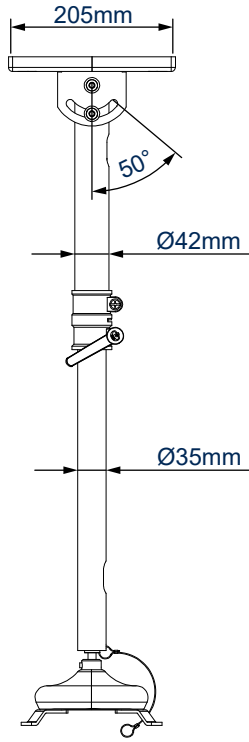

SIDE VIEW

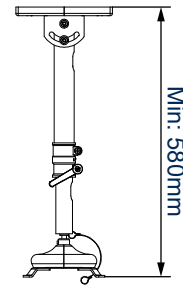

SIDE VIEW - MINIMUM EXTENSION

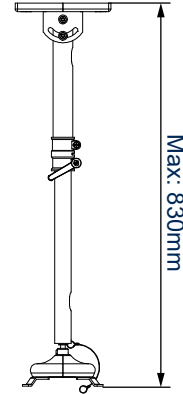

SIDE VIEW - MAXIMUM EXTENSION

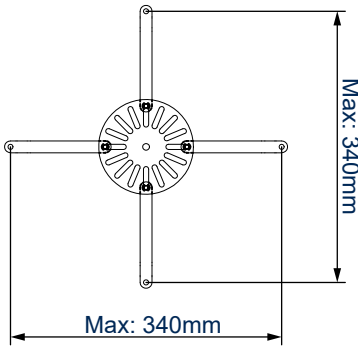

INTERFACE

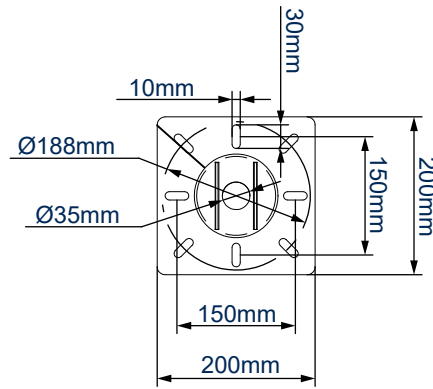

CEILING PLATE

PACKING INFORMATION

COLOUR:	ORDER REF:	EAN CODE:	MASTER CARTON QTY:	INNER CARTON QTY:	MASTER CARTON WEIGHT:	MASTER CARTON CUBE:
Black	BT882/B	5019318088889	2	0	9.4kg	0.03cbm
White	BT882/W	5019318089780	2	0	9.4kg	0.03cbm

ACCESSORIES AND RELATED PRODUCTS



**BT897**  
Stackable Heavy Duty Projector Mount designed for projectors up to 75kg



**BT898**  
Stackable Heavy Duty Projector Mount designed for projectors up to 75kg



**BT899**  
Projector Mount with Micro-Adjustment for projectors up to 25kg

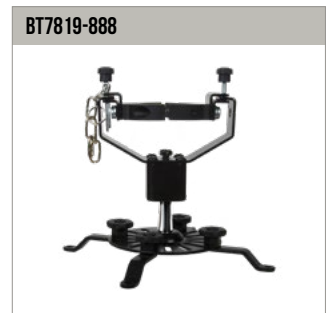

**BT7819-888**  
Universal Projector Mount for projectors up to 15kg

© 2016 B-Tech Professional Design & Manufacturing Ltd. All rights reserved.  
 The information in this specification sheet reflects the current technical specifications of B-Tech Professional Design & Manufacturing Ltd.  
 We warrant the goods to conform to the technical specifications set out in this specification sheet. This B-Tech Professional Design & Manufacturing Ltd.  
 B-Tech Professional Design & Manufacturing Ltd. is not liable for loss or damage caused by improper or negligent installation, use, repair or maintenance of any part of this  
 specification sheet or its contents, unless such loss or damage has been caused by a defect in the goods supplied by B-Tech Professional Design & Manufacturing Ltd.

SS-V4-BT882-050819