



INCREMENTED
 TILT ADJUSTMENT
 UP TO +/-90°

BT883

PROJECTOR CEILING MOUNT

WITH LONG ADJUSTABLE DROP

Designed for projectors up to 10kg, this projector mount is ideal for angled or cathedral ceilings. The BT883 features a unique 'carousel' mounting plate for universal compatibility and a ball joint adjustment that allows easy positioning so a perfectly aligned projection can be achieved. With a maximum ceiling drop of 1330mm, a hand lever provides easy adjustment of the drop once the mount has been fixed into place. Installation is simple with all mounting hardware and fixings supplied, including coverplates for a smart and tidy finish.

SPECIFICATION

Max load	10kg
Tilt (pitch)	+/-90°
Roll	+/-90°
Yaw	360°
Ceiling drop	830 - 1330mm
Max distance between fixings	340mm
Colour option	Black or White

FEATURES

- Suitable for angled / cathedral ceilings
- Designed to mount LCD/LED/DLP projectors up to 10kg
- Features +/-90° tilt, +/-90° roll and 360° swivel so that a perfectly aligned projection can be achieved
- Unique 'carousel' mounting plate for universal compatibility
- Ball joint adjustment for easy positioning of projector
- Hand lever for easy adjustment of ceiling drop, from 830mm to 1330mm
- Quick and easy installation
- Cover plates included for a smart installation
- Steel safety wire included for extra security
- Suitable for projectors with M2.5, M3, M4, M5 and M6 fixings
- All mounting hardware included



Unique 'carousel' mounting plate for universal compatibility



Hand lever for easy adjustment of ceiling drop, from 830mm to 1330mm



Ball joint adjustment for easy positioning of projector



Ideal for angled or cathedral ceilings

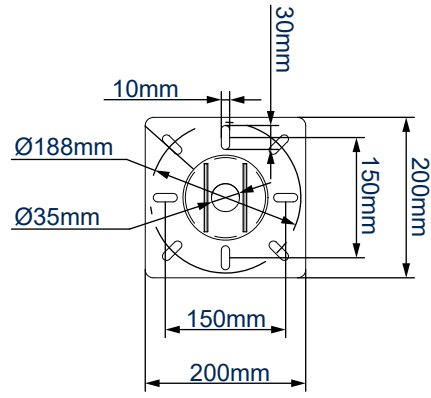
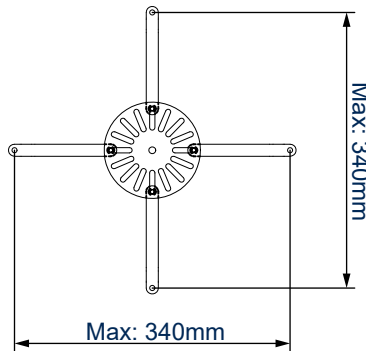
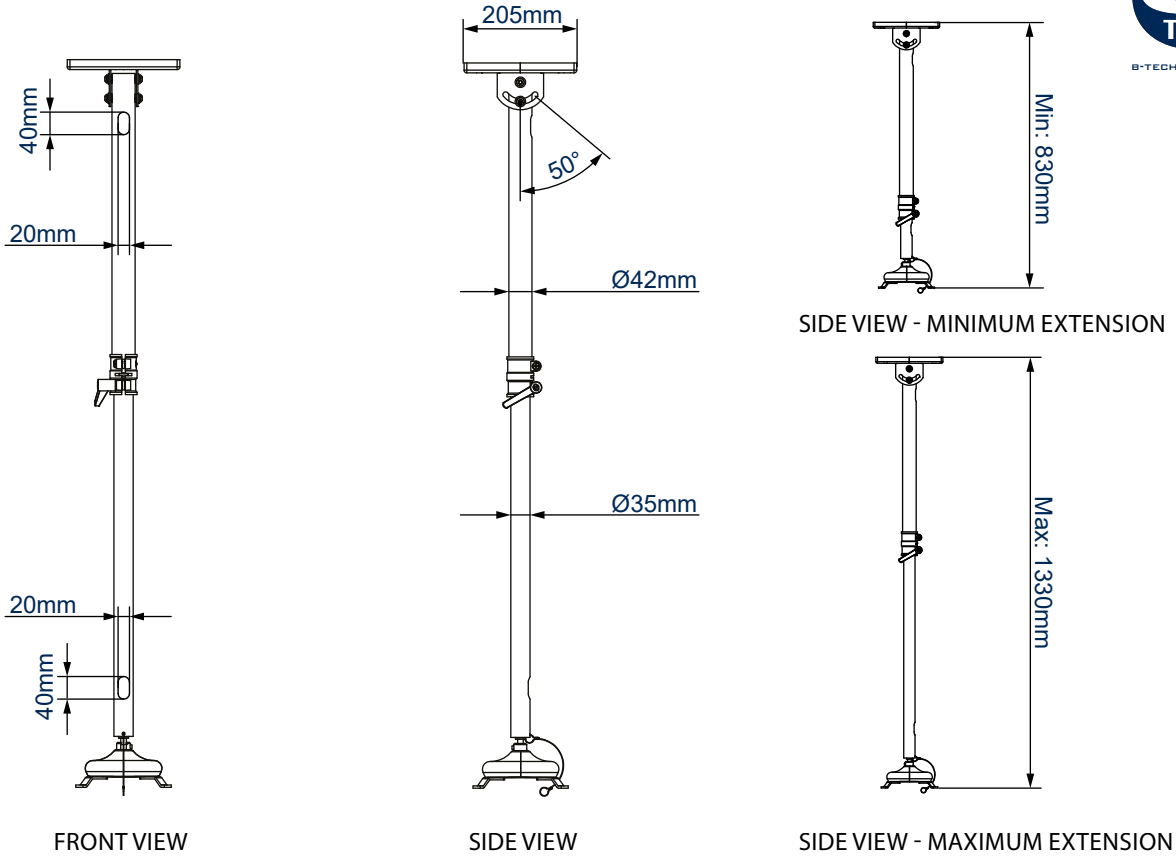

PACKING INFORMATION

COLOUR:	ORDER REF:	EAN CODE:	MASTER CARTON QTY:	INNER CARTON QTY:	MASTER CARTON WEIGHT:	MASTER CARTON CUBE:
Black	BT883/B	5019318088896	2	0	11.3kg	0.043cbm
White	BT883/W	5019318089787	2	0	11.3kg	0.043cbm

ACCESSORIES AND RELATED PRODUCTS



BT897
 Stackable Heavy Duty Projector Mount designed for projectors up to 75kg

BT898
 Stackable Heavy Duty Projector Mount designed for projectors up to 75kg

BT899
 Projector Mount with Micro-Adjustment for projectors up to 25kg

BT7819-888
 Universal Projector Mount for projectors up to 15kg

© 2016 B-Tech International Pty Ltd. All rights reserved.
 The information in this specification is for reference only. It is not intended to be used as a substitute for the manufacturer's instructions. B-Tech International Pty Ltd. is not responsible for any damage or loss of data caused by improper use of the product. Any reproduction or transmission of any part of this specification is strictly prohibited unless prior written permission has been granted by B-Tech International Pty Ltd. (B-Tech).
 SS-V5-BT883-050819